

BALUSTRADE & POOL FENCING**Construction Specification****PART 1 – GENERAL****1.01 WORK INCLUDED**

The contractor shall provide all labour, materials and all necessary items for the installation of the fence system defined herein at _____.

1.02 RELATED WORK

“STM Fences Installation Guide” - Earthwork

“STM Fences Installation Guide” - Concrete

1.03 SYSTEM DESCRIPTION

The Manufacturer shall supply a total stainless steel fencing system of the style, strength and color defined herein. The system shall include all components (i.e. pickets, posts, rails gates and hardware) as required.

1.04 QUALITY ASSURANCE

The contractor shall provide labourers and supervisors who are thoroughly familiar with the type of construction involved and the materials specified.

1.05 REFERENCES

Building Code of Australia 1996 – Volume two.

Australian Standards 1926.1-1993 – Swimming Pool Safety.

ANSI A1264.1-1995 – Safety Requirements for Workplace Floor and Wall openings, Stairs and Railing Systems.

1.06 SUBMITTAL

The manufacturer’s literature shall be submitted prior to installation to confirm compliance with all requirements for materials specified in this section.

1.07 PRODUCT HANDLING AND STORAGE

Upon receipt at the job site, all materials shall be checked to ensure that no damages occurred during shipping or handling. Materials shall be stored in such a manner to ensure proper ventilation and drainage and to protect against damage, weather, vandalism and theft.

PART 2 - MATERIALS**2.01 MANUFACTURER**

The stainless steel fencing system shall conform to all various styles available.

2.02 MATERIAL

- A. Tubing: All tubing shall be made from 304 & 316 stainless steel. They shall be polished to a high-grade buff polish.
- B. Fasteners: All screws shall comprise of 303, 304 or 316 stainless steel

- C. Inserts: Nut inserts shall be made from 304 stainless steel. Aluminium inserts shall be made of 2011 T6.
- D. Fittings: All fittings for balustrade construction shall be made of 304 or 316 polished stainless steel.
- E. Accessories: Stainless steel shall be used for all post caps, wall brackets and other miscellaneous hardware. Hinges shall be fabricated from stainless steel, while gate latches shall be Nylon as supplied from Magna-Latch

2.03 FABRICATION

- A. Top and bottom horizontal rails shall be Ø2” x 0.060” thick and shall be punched on one side only, to allow balusters to pass through.
- B. Balusters shall be Ø½” x 1.6mm thick and each end shall be fitted vertically into the punched holes in the top and bottom 2” tube rails.
- C. After ½” balusters have been fitted into the 2” tube, expanding foam is injected into the open ends of the 2” tube. After the foam has set, the ½” balusters are now locked in place and the balustrade panel is now stiff and ready for installation.
- D. Posts shall be Ø2” tube x 1.6mm thick. Stainless steel post caps shall be affixed to all posts. Stainless steel cones shall be used to attach rails to posts.
- E. The use of expanded foam to secure ½” tube to 2” tube is a Patented process by STM Fences.

PART 3 - EXECUTION**3.01 PREPARATION**

The contractor, in accordance with the construction plan, shall carry out all new installations.

3.02 INSTALLATION

Balustrade and fencing posts shall be set in accordance with the spacing as determined by the fencing system supplier. A sophisticated computer program is used to determine the ideal post spacings for all possible fence designs. The “Earthwork” and “Concrete” sections of this specification shall govern post-base placement and material requirements. Stainless Steel panels shall be attached to walls and posts using cones and fasteners supplied by the manufacturer.

3.03 CLEANING

The contractor shall clean the jobsite of excess materials. Posthole excavations shall be scattered uniformly away from posts. No acid based cleaning solutions should be used on or near the posts as these react with the stainless steel and will discolor and stain them.

**STM FENCES - COMMERCIAL BALUSTRADE
& POOL FENCING
LIMITED LIFETIME WARRANTY**

STM Fences' commercial balustrade and pool fencing is manufactured from the high quality materials using world-class process machinery. The panels are assembled by skilled artisans and meet the highest standards of workmanship in the industry. Our welded and cold worked 2" tube is polished to a high quality fine bright finish. This gives the tube surface a superb finish, which offers best resistance to 'tea-staining' near coastal areas.

STM Fences balustrade and pool panels, posts and fittings are guaranteed under normal and intended usage, against cracking or corroding commencing from the original purchase date and extending according to the applications defined in the table below. Normal and intended usage does not include physical damage, abrasion, staining due to acid/chemical contact. For optimum results, the system should be washed and cleaned with a mild detergent, followed by towel drying. It is recommended that the fence be cleaned monthly.

This warranty applies to all STM Fences products.

The following acts and/or omissions will void the subject warranty:

- Damage to the product caused by the property owner by use of landscape, gardening equipment, chemicals and/or water sprinklers with high mineral content. (Do not stand or climb on any part of the gate or fence/balustrade panels);
- Damage caused by allowing plant life of any sort to grow directly upon or in contact with any portion of the product or sap from trees;
- Any alteration to the product itself by the property owner including any on-site cutting or welding;
- Failure to follow any and all maintenance instructions provided by STM Fences at the time of sales to the original purchaser even if these instructions are not forwarded to the ultimate claimant under this warranty.

STM Fences' fencing products are guaranteed for the same period of time against defects in workmanship or materials. Should any STM Fences product fail in accordance with any of the above conditions, STM Fences warrants to the original purchaser their redemption through replacement, renewal or issuance of a pro-rata credit. The choice of redemption method is solely at the discretion of STM Fences. If the pro-rata alternative is chosen, the amount will be based on the original cost of materials at the date of purchase, multiplied by the appropriate time and exposure factor from the table below.

<i>Application</i>	<i>Length of Warranty</i>
<i>All Gates & Associated Fittings</i>	<i>5 Years</i>
<i>Magna Latch & Associated Fittings</i>	<i>1 Year</i>
<i>Balustrade / Pool fence installations 0 to 1 km from Salt Water Coast Line</i>	<i>5 Years</i>
<i>Balustrade / Pool fence installations 1 to 20 km from Salt Water Coast Line</i>	<i>12 Years</i>
<i>Balustrade / Pool fence installations Over 20 km from Salt Water Coast Line</i>	<i>15 Years</i>

Notice of failure under the conditions of this warranty shall be sent to STM Fences or it's authorised representative, in writing, together with proof of purchase and shall specify the nature of the defect and when it was first observed as well as photographs of current site conditions. Should the balustrade/fence be improperly installed, STM Fences shall not be responsible for guaranteed performance or appearance of the material. Neither does this guarantee apply when failure or damage is due to improper use or application, abuse or misuse, acts of God, possible global warming induced hurricanes or "tea staining". STM Fences reserves the right to inspect the material to determine validity of the claim.

Upon acceptance of the claim by STM Fences or its authorised representative, STM Fences shall make redemption by replacement, renewal or issuance of a pro-rata credit. Reimbursement for the cost of removal of existing material and the freight and installation of replacement material is not included in the guarantee, nor will STM Fences provide these services.

The above constitutes the complete warranty by the manufacturer. No other agreement, written or implied is valid. STM Fences does not authorise any other person or agent to make any other express warranties. STM Fences neither assumes nor authorises any other person or agent to assume any other liability in connection any range of STM Fences fencing system.

PURCHASE DATE _____

DEALERS SIGNATURE _____

***** NOTE *****

***** All tube can be either supplied CORE-DRILL length or standard BASEPLATE mounted length. The exceptions are all gates; they are all supplied CORE-DRILL length. *****

Tubular Balustrade Design

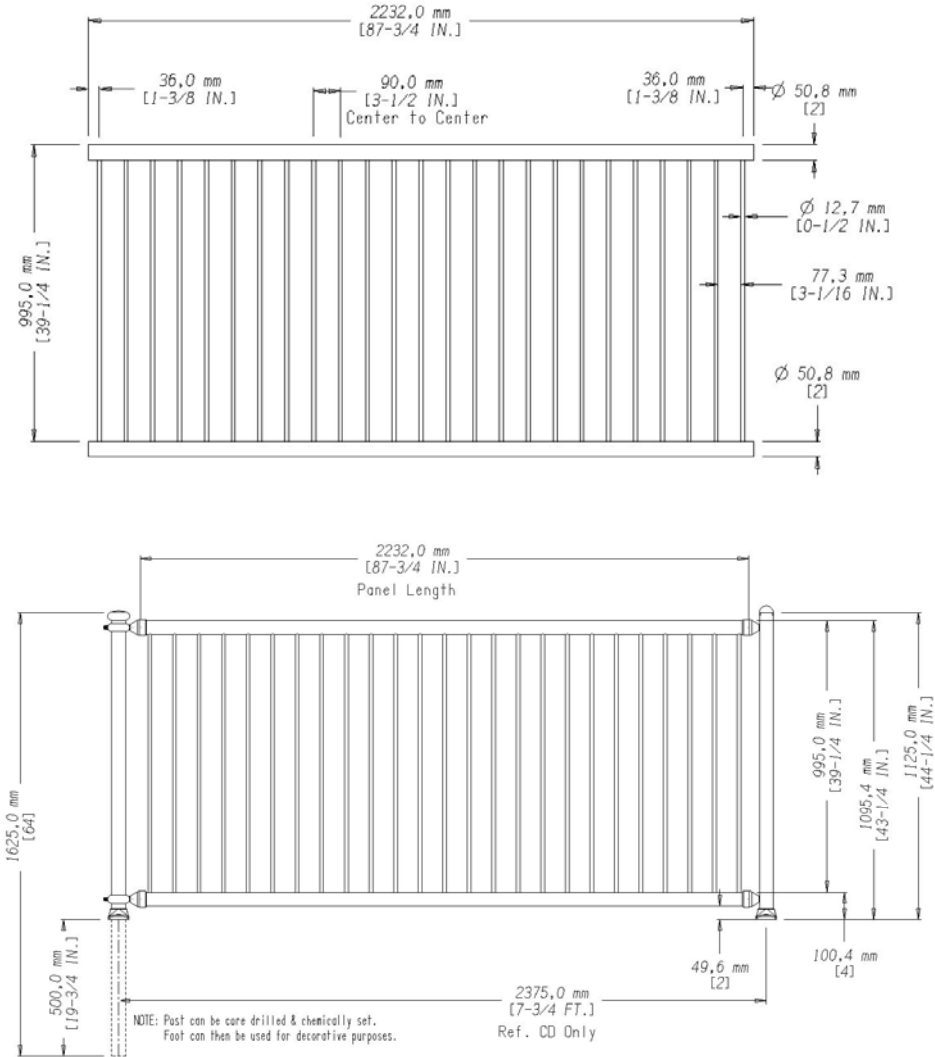

Tubular Pool Fence Design

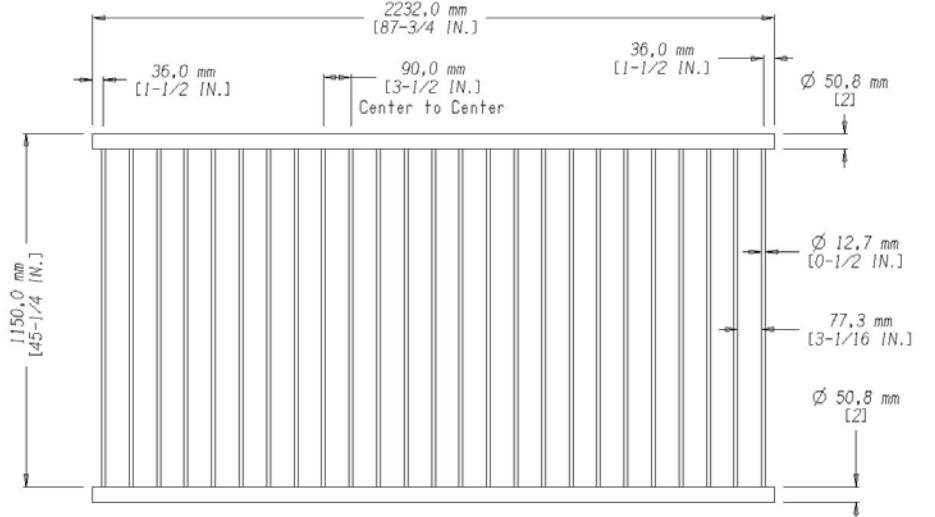

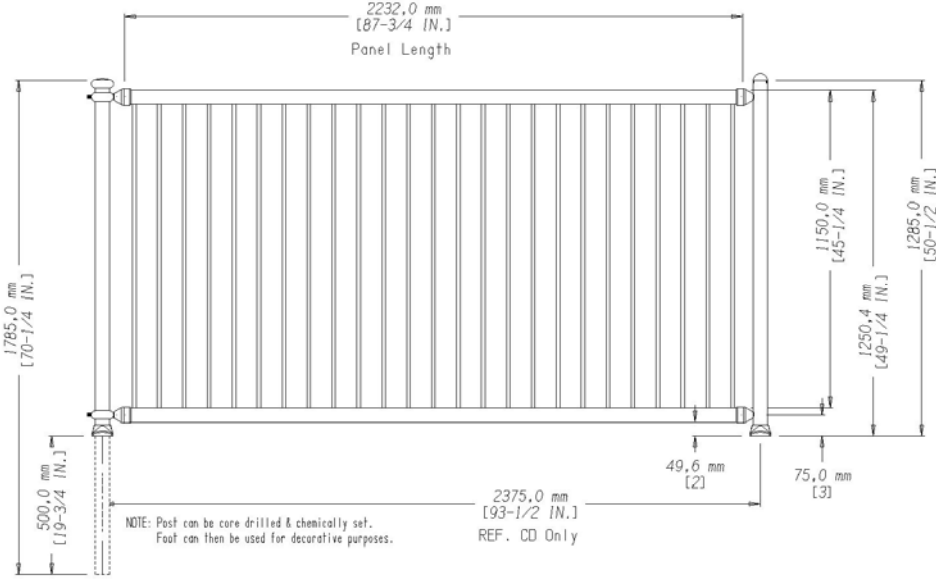

Tubular Pool Fence Gates

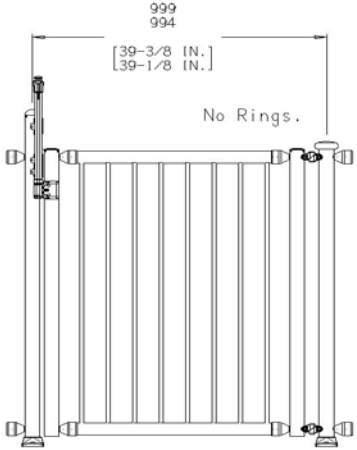
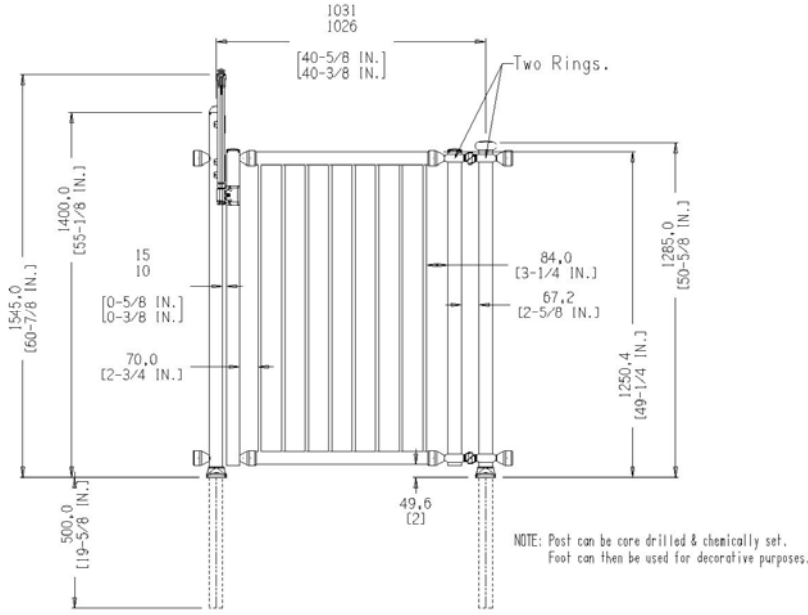

NOTE: Post can be core drilled & chemically set.
Foot can then be used for decorative purposes.

Glass Balustrades

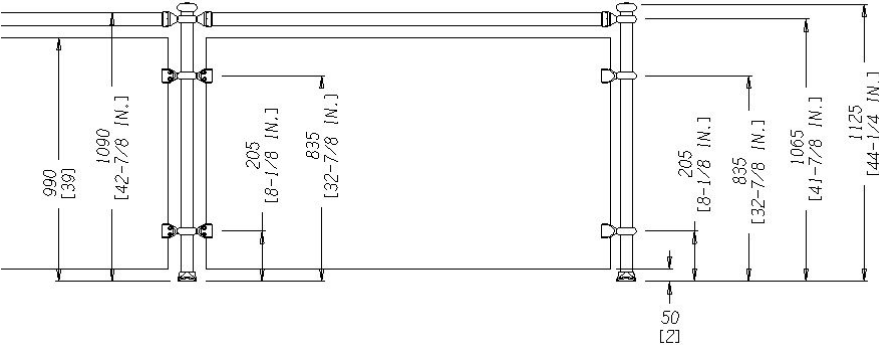

Glass Pool Fences

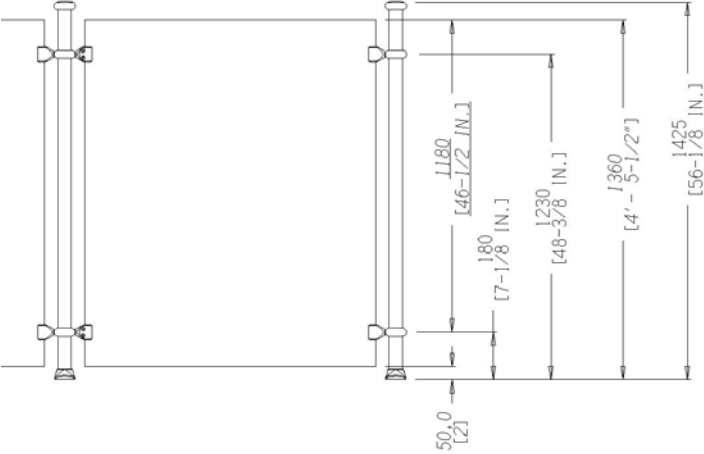

Glass Pool Fence Gates

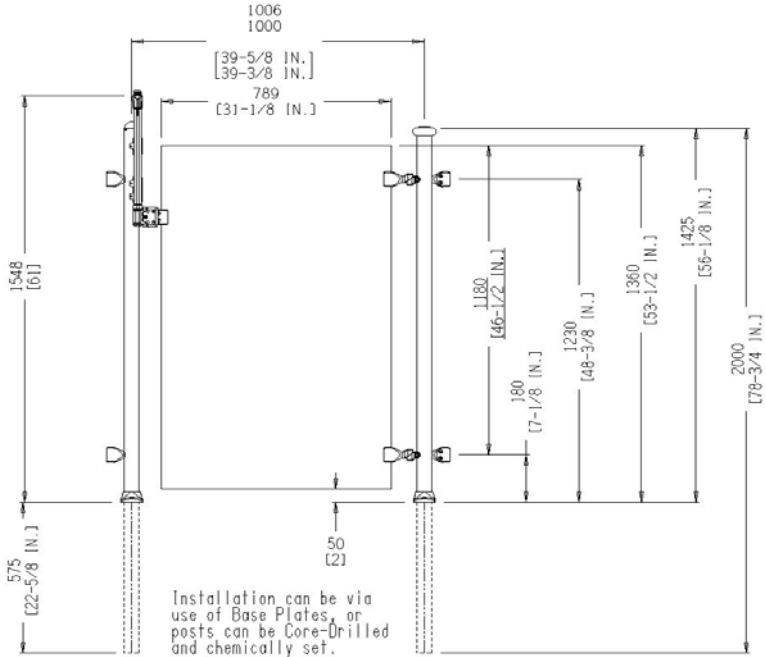

Post Cap Styles		
Capped Collar	Flat Cap	Domed Cap
